

# STATIC ELIMINATOR

## FEATURES:

1. Wash deck is designed by Venturi principle to remove powder effectively.
2. Equipped with static generator in the air outlet to separate material & powder.
3. Improve the cleanliness of the raw materials, reduce the carbonation problem of plastic powder melted, thereby enhancing the product quality.
4. Equipped with transparent window to check the operating process of static eliminator.
5. Auto-cleaning dust collector is equipped with cartridge filter.
6. The bottom of the dust collector mounted movable dust cleaning barrel.
7. Material output of static eliminator can be adjusted according to material consumption.
8. With cartridge & HEPA filters to ensure the cleanliness of air source.
9. Well designed protector for electricity, motor and material storage alarm.



## FLOWCHART:

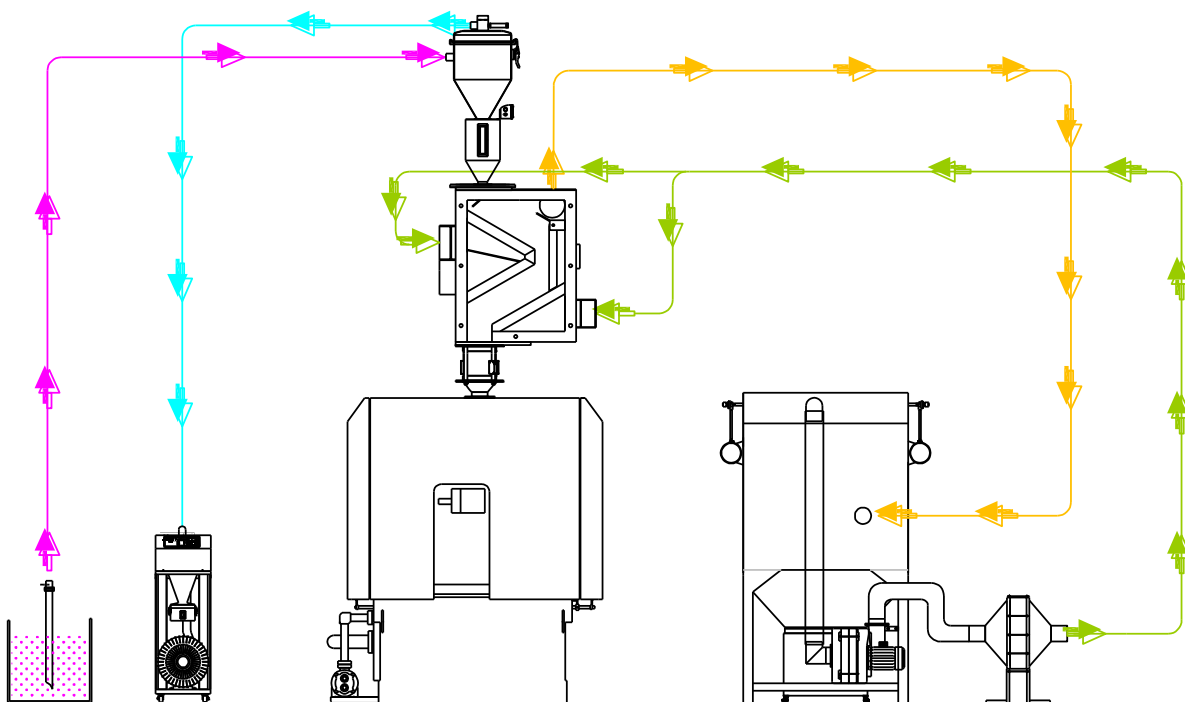



## SPECIFICATIONS

Model			KFS-100	KFS-800	KFS-1800
Capacity	KG/HR		100	800	1800
Blower	60HZ	KW	0.4	1.5	2.6
	50HZ		0.4	1.5	2.2
Outlet wind pipe diameter	INCH		2	4	6
Total load	60HZ	KW	1.2	2.9	3.6
	50HZ		1.2	2.8	3.2
Dimension	Static eliminator	W	45	50	120
		D	20	25	60
		H	45	60	145
	Auto-cleaning dust collector	W	105	110	165
		D	50	100	160
		H	130	245	250
	HEPA filter	W	35	75	95
		D	35	70	80
		H	70	90	100
Compressed air	MM		Over $\phi$ 5*8MM at 6KG/CM <sup>2</sup>		
	LPM		30		
Approx. weight	Static eliminator	KG	20	80	130
	Auto-cleaning dust collector	KG	90	600	900
Options	1.Auto loader 3.Demumifying dryer		2.Central material receiver with window stand 4. Insulated & dust-free hopper dryer		
Remarks	1.We reserve the right to change specifications without prior notice.				