

MATERIAL RECEIVER WITH WINDOW STAND

FEATURE :

1. Construction is made of SUS304, prevent material pollution.
2. Material level sensor is equipped with magnetic switch and the wide-mouth flap design to ensure materials flow smoothly and can be conveyed stably.
3. Window stand is adopted clearance maintenance door design which material shortage and full material are visible. Also, easy to do maintenance and make sure dehumidifying effect of closed circulation.

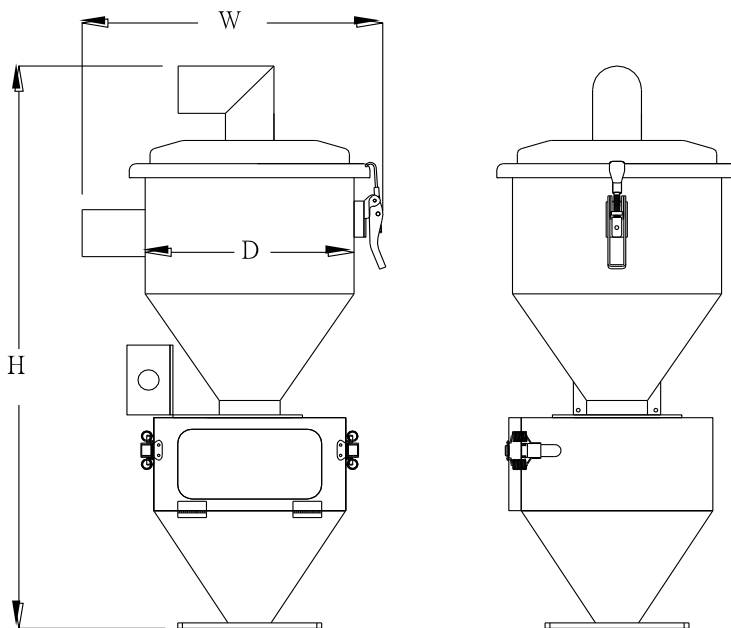

SPECIFICATION

Model	Level sensor	Capacity (LITER)	Buffer capacity (LITER)	Approx. weight (KG)	Dimension (CM) (W*D*H)	Connection Base (MM)
KMR-6W	Magnetic Switch	6	4	7.5	32*22*61	120*120
KMR-15W		15	8	11.5	42*32*78	120*120
KMR-30W		30	8	17	42*32*108	120*120
Remark	1. We reserve the right to change specifications without prior notice.					