

CENTRAL LOADER

FEATURES:

1. Central loaders with continuous operation are designed to protect motors.
2. Auto pressure-relief device is designed for safety consideration.
3. For the purpose of material can be conveyed stably, two central loaders are designed to interchange automatically.



KCL -R SERIES



KCL SERIES

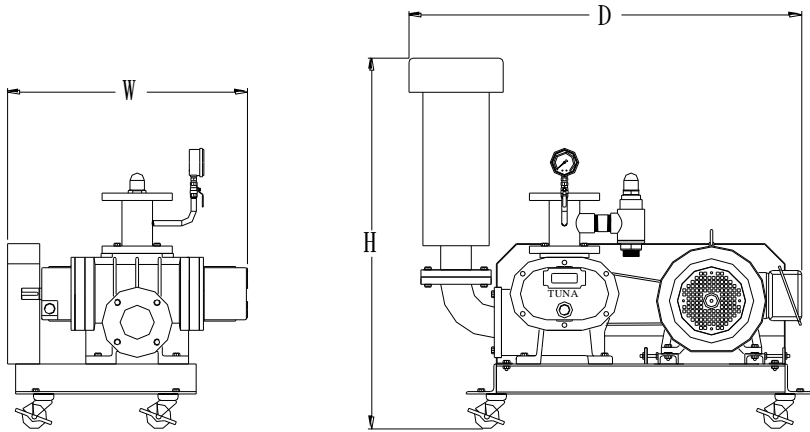

SPECIFICATIONS

MODEL			KCL-250 KCL-50R	KCL-275 KCL-75R	KCL-2100 KCL-100R	KCL-2150 KCL-150R	
Blower	Type	KCL	Two-stage blower				
		KCL-R	Roots blower				
	Power	KCL(60/50HZ)	KW	3.7 / 3.4	6.3 / 5.5	8.6 / 7.5	13.0 / 11.0
		KCL-R		3.75	5.6	7.5	11.3
Dimension (W*D*H)	KCL	CM	55*75*90	65*80*95	65*80*95	75*85*100	
	KCL-R		65*85*88	73*97*122	73*97*122	80*106*131	
Approx. weight	KCL	KG	60	90	105	165	
	KCL-R		148	230	245	305	
Remarks			1. We reserve the right to change specifications without prior notice. 2. The design of central loader depends on conveying conditions & power frequency.				