

# Bag Emptying Machine with Bale Press

## Description

- With the fully automatic bag emptying machine, granulate bags of 25 kg can be opened and emptied into a receiving bin.
- The capacity of the machine is between 10 and 15 tons of granules per hour.
- Emptying is better than 99.98%!
- It is also possible to transport or drop the empty bags (in) to a bag compactor or baler.
- The granulate in the receiving bin is transported from the bin by means of a granulate pump into the pneumatic transport system.
- This system provides a durable and reliable transport to storage silos.



## Feature:

- Expandability: possibility to
  - Add a bag compactor
  - Add a pallet stacker
  - Implement in complex control system with full process control
- Flexibility (additional options, executions can be discussed)
- Robust execution
- Separated steady movements
  - Electrical lift executes vertical movement
  - Shuttle executes horizontal movements



科基企業有限公司

橡膠輔機設備專業製造、中央供料暨整廠自動化系統規劃執行  
Email: tigerkj@ms15.hinet.net [www.tigerkj.com.tw](http://www.tigerkj.com.tw)

## Layout:

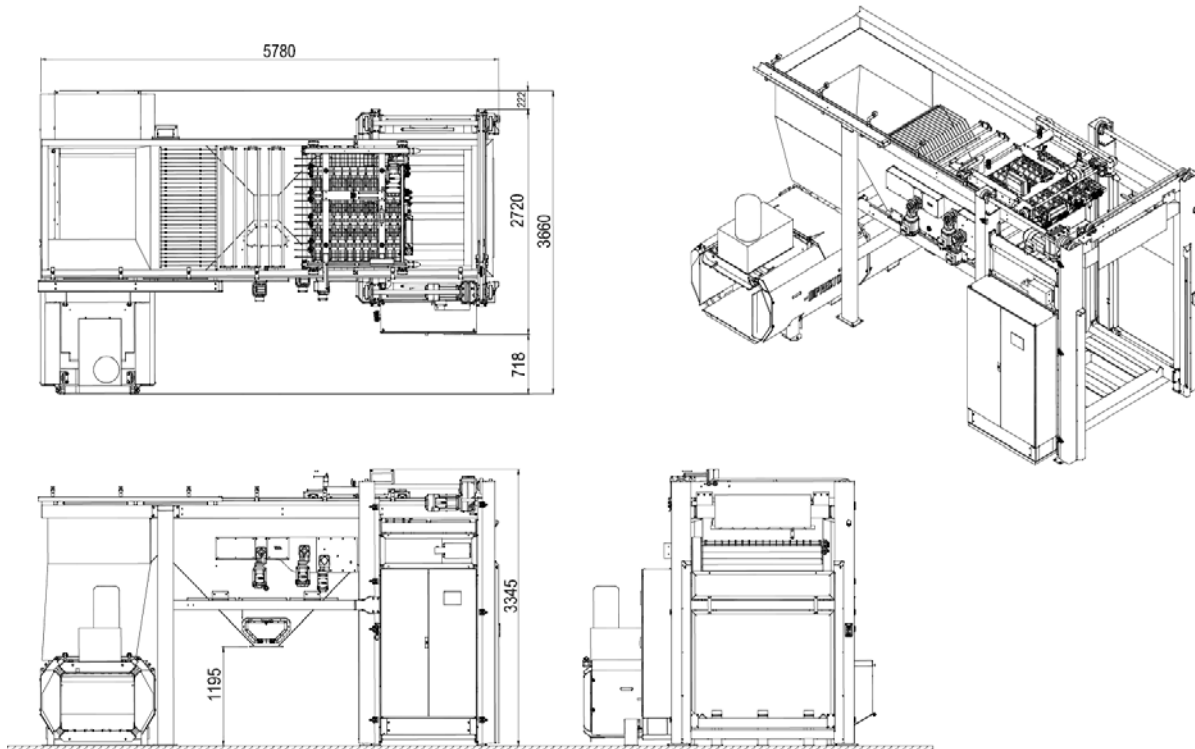

## Alternative designs and extra options:

- XL unit: Suitable for dumping granulate into containers, bigbags, octabins or truckloads
- Automated cleaning: This machine can clean itself after a batch, so it is immediately ready for a different product
- Automatic pallet transport (in and out)
- Integrated palletstacker for stacking the empty pallets
- Integrated bag compactor or baler for the empty bags

## Specification of Bale Press:

- Feeding opening L x W: 1030x950 mm
- Channel W x H: 950 x 700 mm
- Dimensions L x W x H: 3550 x 1410 x 1940 mm; without hopper
- Max. feeding volume: 0,68 m<sup>3</sup>
- Volume throughout in idle speed: 72 m<sup>3</sup>/h without binding time
- Pressing force: 300 KN; specific pressing force: 45 N/cm<sup>2</sup>
- Cycle time: 34 s
- Drive power uptake: 11 KW; fuse: 35 A; delay melting fuse
- Power connection: 460 V, 60 Hz
- Channel outlet fully automatic control
- Binding system: manual, 4-fold; binding with polyester strap reels
- Low oil level switch with over temperature stop function
- Equipped with Operating hour meter and Bale length meter
- Starting system by light barrier - Hydraulic central drive
- Central control system with function and failure display by Siemens PLC control
- Bale length pre-selection via text display
- Revision door (670x670mm) with Plexiglass
- Total Load: 11 KW



科基企業有限公司

橡膠輔機設備專業製造、中央供料暨整廠自動化系統規劃執行  
Email: tigerkj@ms15.hinet.net [www.tigerkj.com.tw](http://www.tigerkj.com.tw)

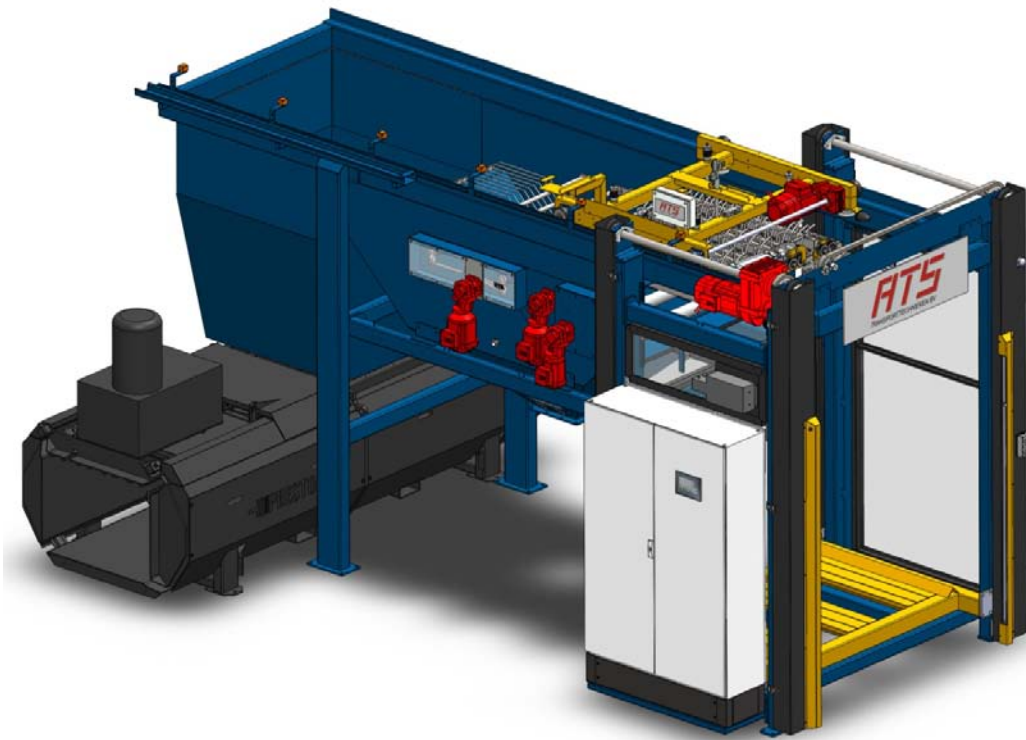
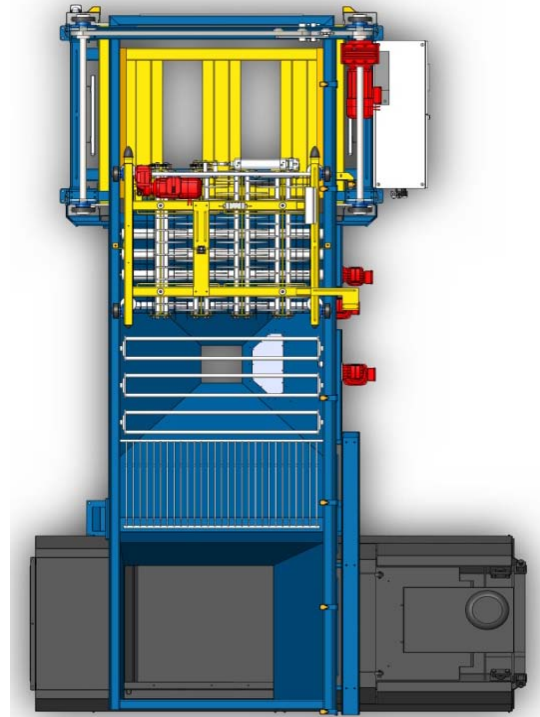
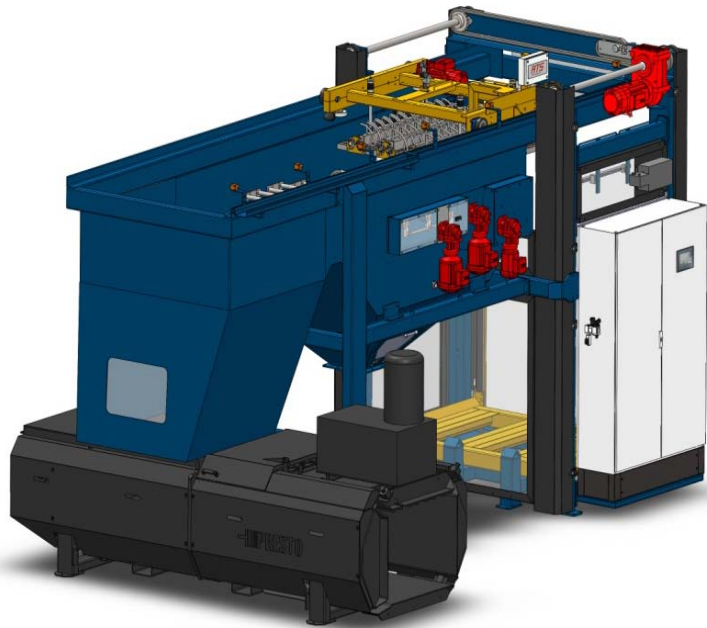

## Bag Emptying Machine with Bale Press